

The first security guard for your household water now is available



Product purpose

The target of water treatment station is for reducing the turbidity, iron and manganese content in the well water, meanwhile, using UV light to kill the bacterias in it.

Product features and benefits

- + 3 modes (working mode, flushing mode, back flushing mode) with one valve control, easy operation.
- + 4 stages of filtration can effectively reduce the turbidity, iron, and manganese.
- + Big capacity UV light can kill bacterias effectively.
- + Easy installation, free maintain.

Filtration Technology

- + 2-layer quartz sand can realize preliminary interception of large solids, sediments, algae and moss.
- + One additional layer garnet help to block more small particles, worm eggs.
- + Activated carbon absorb bad color and odor, chlorine.
- + UV light can kill bacterias.

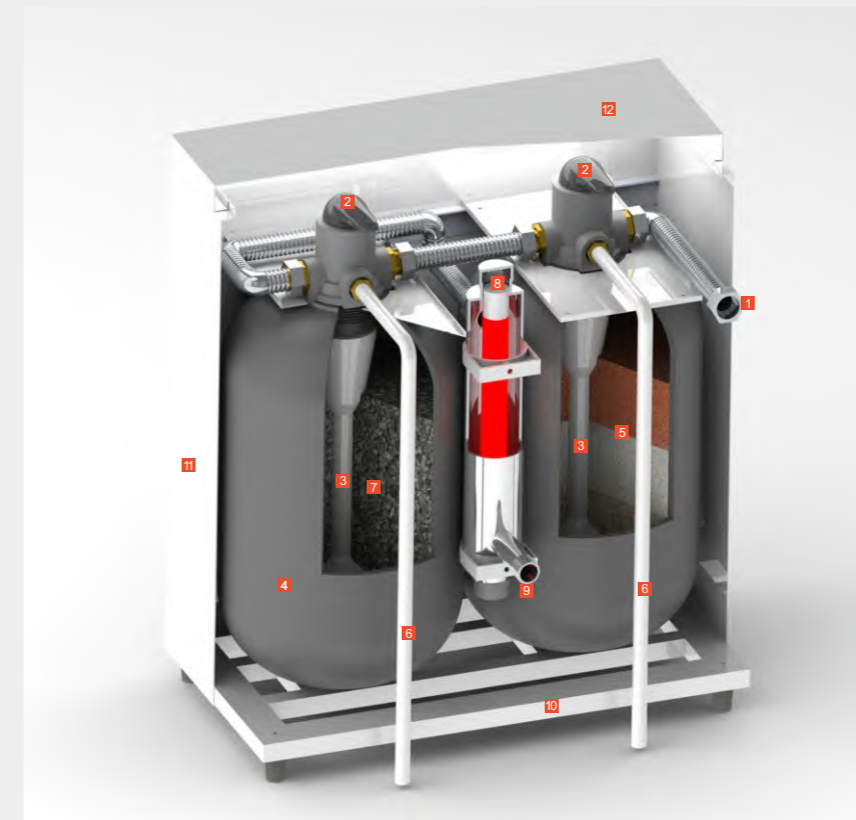

Water treatment station S2-2G

- 1 Water inlet
- 2 Valve set
- 3 Central tube
- 4 Filter tank
- 5 filter material
- 6 Drainage
- 7 Activated Carbon
- 8 Ultraviolet
- 9 Water outlet
- 10 Fixing frame
- 11 Housing
- 12 Upper cover

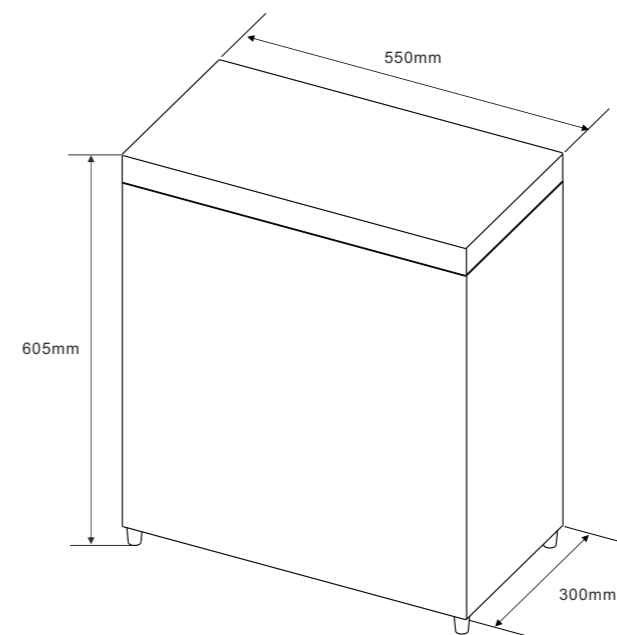

Technical data

- Water source:**
Water
- Filter material:**
Quartz sand
Garnet
Activated carbon
- Flow rate (l/min):**
8-33l/min
- Inlet/outlet pipe:**
DN 20
- Drainage pipe:**
DN15
- Dimension HxWxD (mm):**
605X550X300
- Weight (kg):**
36
- Power:**
220V/50Hz